

# housing tailored design

# contact us for further information



INCINERATORS

What are your Options? What do the regulations stipulate?

## TURCO Incinerator Housing

Turkington Engineering Limited has an alternative that is cost effective, easily assembled and facilitates both the incinerator and the oil tank – All you need is a concrete base and bund for the oil tank.



**Dimensions:** Height 2.2 m  
Width 3.5 m  
Length 4.5 m

Turkington Engineering is a privately owned company established for 40 years. During this time we have built a reputation as one of the leading UK Manufacturers of Incinerators.

From our new cutting edge 40,000 sq.ft. production facility, we offer reliability, versatility and the peace of mind you would expect from a company at the forefront of technology.

ISO accreditation guarantees quality and professionalism across our business, from the products we manufacture to the service we deliver.

For further technical information or a quotation please contact:

Manufactured by:  
**TURKINGTON ENGINEERING LIMITED**  
14 TULLYLAGAN ROAD, SANDHOLES  
COOKSTOWN, CO TYRONE. BT80 9AZ  
Tel: 028 867 63372 / ROI: 048 867 63372

E-mail: [info@turco.co.uk](mailto:info@turco.co.uk) / [www.turcoboilers.com](http://www.turcoboilers.com)

Turkington Engineering Limited have a continued research and development programme which occasionally necessitates changes to specifications herein.

Copyright of the contents of this brochure is secured by Turkington Engineering Limited and therefore no part of it may be reproduced without permission.



**Efficient 'on the spot' Animal and Poultry carcass & waste disposal**



Design tailored to give weather protection to Incinerator.  
Houses Oil Tank on a bunded base.

# warranty peace of mind

## 12 MONTH WARRANTY (Parts & Labour)

Subject to the incinerator being commissioned on Installation and serviced after 6 months by a Turco Approved Engineer. (Included in price)

A nationwide network of fully qualified registered service engineers supports every warranty... so in the unlikely event of a problem all you need to do is contact us.

Spares - We stock a full range for all incinerators.

**'Manufacturing with experience'**

**40 years in engineering**

**15 years design & manufacture of Incinerators.**

Model	T1	T3
Weight (Kg)	1100	1760
Load Capacity (kg)	200	400
Burn Cycle (hours)	4½	8½
Oil Usage (Litres/Hr)	8 Approx	8 Approx
Volume (m <sup>3</sup> )	0.39	0.87

### The T1 Model

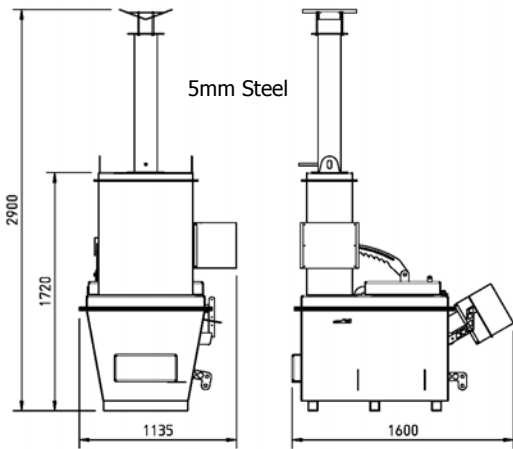

### The T3 Model

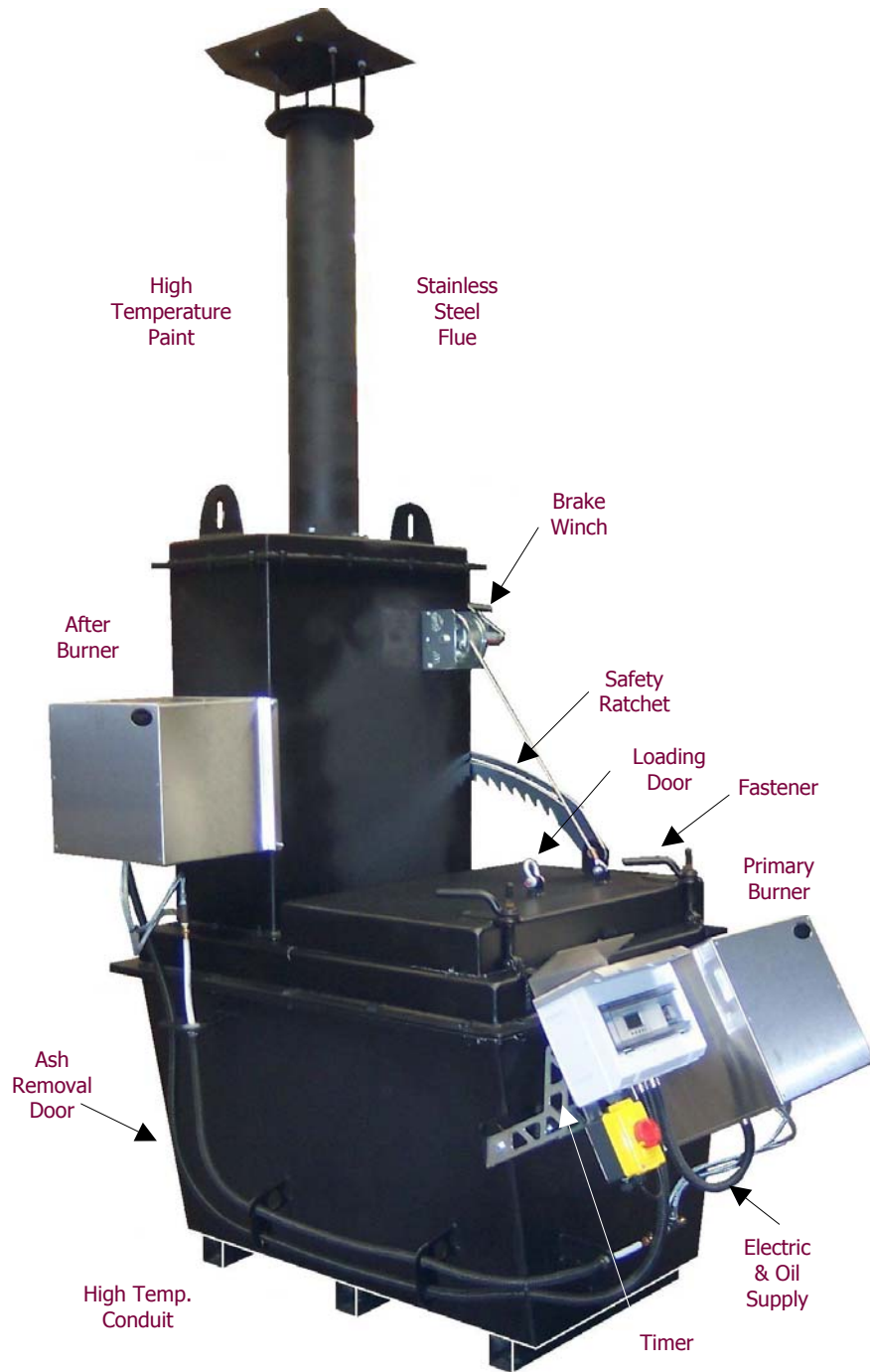
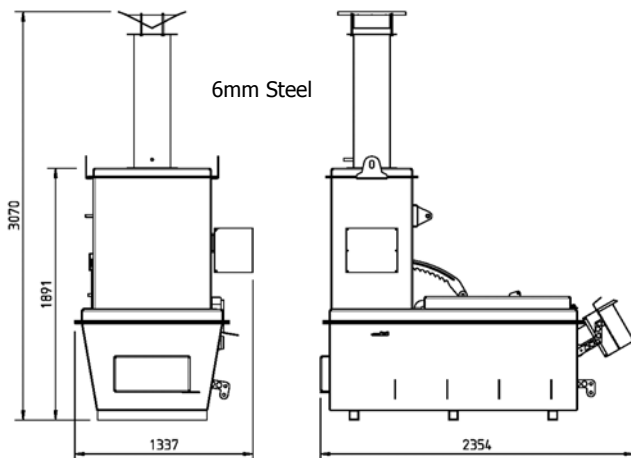

### Key Features:

- Simple on site installation
- Easy top loading of carcasses
- Efficient, low-cost disposal
- Controlled environmental emissions
- Low maintenance costs
- Clean Out Door for removal of ash
- No 'Rams' used on the doors since five years ago as they were unsatisfactory
- We have our own burner engineers
- Stainless Steel tube used on Flues
- Automatic Timer
- Temperature Monitoring Point
- Door Opening Winch & Safety Ratchet

**DEFRA / DARD "Type Approved"**

Brake Winch



Door Safety Ratchet



Loading Door



Temp. Monitoring Point



Controls & Primary Burner

